



Fred/吴早顺

General Director

 No. 3, Xiangfeng Rd. Miubian Village, Liaobu Town, Dongguan, 523423, Guangdong, China

 +86 13736991831  13736991831

 info@seonsing.com www.seonsing.com  fredwu577

东莞顺成智能科技有限公司
Dongguan Seonsing Intelligent Tech Co., Ltd

SGS CE EMC LVD

Certifications

SGS SGS-CSTC Standards Technical Services Co., Ltd. Guangzhou Branch

188 Xinhui Road, Sionmen Park, Guangzhou Economic & Technological Development Zone, Guangzhou, China 510663
 Telephone: +86 (0) 20 27155555
 Fax: +86 (0) 20 80706666
 Email: mg.guangzhou@sgs.com

Page 1 of 1

VERIFICATION OF EMC COMPLIANCE

Verification No.: GZEM2001010307HSV
 Applicant: Dongguan Seansing Intelligent Tech Co., Ltd.
 Address of Applicant: Floor 2 Building B No. 3, Xiangfeng Rd, Mubian Village, Liacou Town, Dongguan, Guangdong, China
 The same as applicant
 Manufacturer: The same as applicant
 Address of Manufacturer: The same as applicant
 Factory: The same as applicant
 Address of Factory: The same as applicant
 Product Description: Hand dryer
 Model No.: SHD1811, SHD1812, SHD1815
 Sufficient samples of the product have been tested and found to be in conformity with Test Standard(s): EN 55014-1:2017
 EN 61000-3-2:2019
 EN 61000-3-3:2013
 EN 55014-2:2015

As shown in the Test Report Number(s): GZEM200101030701

The verification of EMC Compliance has been granted to the applicant based on the results of the tests, performed by laboratory of SGS-CSTC Standards Technical Services Co., Ltd. on the sample of the above-mentioned product in accordance with the provisions of the relevant specific standards under Directive 2014/53/EU.

The CE mark on above-mentioned can be used, under the responsibility of the manufacturer, after completion of an EU Declaration of Conformity and compliance with all relevant EU Directives.

John J. Sun
 John J. Sun
 EMC Laboratory Manager

CE

Date: 2020-07-07

SGS

SGS-CSTC Standards Technical Services Co., Ltd. is a member of the SGS Group of Companies. The SGS Group of Companies is a leading provider of testing, inspection and certification services to the global market. The SGS Group of Companies is a member of the SGS Group (SGS SA).

SGS

TEST REPORT

Applicant: Dongguan Seansing Intelligent Tech Co., Ltd.
 Address: Floor 2 Building B No. 3, Xiangfeng Rd, Mubian Village, Liacou Town, Dongguan, Guangdong, China

The following sample(s) was (were) submitted and identified by client as:

Sample Description: Soap dispenser
 Model No.: SPC3108, SPC3108, SPC3108, SPC3110, SPC3110, SPC3110, SPC3110, SPC3110, SPC3110
 Sample Received Date: September 04, 2020
 Testing Period: From September 01, 2020 to September 06, 2020
 Test Request: Please refer to next page(s)
 Test Result(s): Please refer to next page(s)

Signed for and on behalf of Shenzhen SJS Testing Technology Co., Ltd.

Prepared by: *Shanying* Checked by: *Emily*
 Shanying Lin Emily Wang
 Engineer Supervisor

Shenzhen SJS Testing Technology Co., Ltd.
 69 Floor, Building 3, Tech 2 Commerce Center, No. 2 Lamai Street, Huihan Community, Longhua Street, Longhua District, Shenzhen, China
 Telephone: +86 (0) 755 2776 4461 Fax: +86 (0) 755 2776 4461 E-Mail: service@sjslab.com

证书号 0940464 号

外观设计专利证书

外观设计名称: 横向往手器
 设计人: 郑威军
 专利号: ZL 2019 3 0635260.0
 专利申请日: 2019年11月18日
 专利权人: 东莞顺威智能科技有限公司
 地址: 523000 广东省东莞市寮步镇边社区祥丰路3号B栋2楼

授权公告日: 2020年07月14日 授权公告号: CN 305923838 5

国家知识产权局依照中华人民共和国专利法经过初步审查, 决定授予专利权, 颁发外观设计专利证书并在专利公报上予以公告, 专利权自授权公告之日起生效, 专利期限为十年, 自申请日起算。

专利证书记载专利权的法律状况, 专利权的转移、质押、无效、终止、恢复和专利权的归属及名称、国籍、地址变更等事项记载在专利公报上。

局长 *申长雨*
 申长雨

2020年07月14日

第1页(共2页)

其他事项参见续页

证书号 0946409 号

外观设计专利证书

外观设计名称: 总成分配器
 设计人: 郑威军
 专利号: ZL 2019 3 0635262.X
 专利申请日: 2019年11月18日
 专利权人: 东莞顺威智能科技有限公司
 地址: 523000 广东省东莞市寮步镇边社区祥丰路3号B栋2楼

授权公告日: 2020年07月14日 授权公告号: CN 305923776 5

国家知识产权局依照中华人民共和国专利法经过初步审查, 决定授予专利权, 颁发外观设计专利证书并在专利公报上予以公告, 专利权自授权公告之日起生效, 专利期限为十年, 自申请日起算。

专利证书记载专利权的法律状况, 专利权的转移、质押、无效、终止、恢复和专利权的归属及名称、国籍、地址变更等事项记载在专利公报上。

局长 *申长雨*
 申长雨

2020年07月14日

第1页(共2页)

其他事项参见续页

证书号 0917302 号

外观设计专利证书

外观设计名称: 竖向出风干手器
 设计人: 郑威军
 专利号: ZL 2019 3 0635291.5
 专利申请日: 2019年11月18日
 专利权人: 东莞顺威智能科技有限公司
 地址: 523000 广东省东莞市寮步镇边社区祥丰路3号B栋2楼

授权公告日: 2020年07月03日 授权公告号: CN 305891922 5

国家知识产权局依照中华人民共和国专利法经过初步审查, 决定授予专利权, 颁发外观设计专利证书并在专利公报上予以公告, 专利权自授权公告之日起生效, 专利期限为十年, 自申请日起算。

专利证书记载专利权的法律状况, 专利权的转移、质押、无效、终止、恢复和专利权的归属及名称、国籍、地址变更等事项记载在专利公报上。

局长 *申长雨*
 申长雨

2020年07月03日

第1页(共2页)

其他事项参见续页

证书号 11240037 号

实用新型专利证书

实用新型名称: 一种带保护盖板和技术室的制冰式分流配水器
 发明人: 郑威军
 专利号: ZL 2019 2 1994296.2
 专利申请日: 2019年11月18日
 专利权人: 东莞顺威智能科技有限公司
 地址: 523000 广东省东莞市寮步镇边社区祥丰路3号B栋2楼

授权公告日: 2020年08月14日 授权公告号: CN 21243100 8

国家知识产权局依照中华人民共和国专利法经过初步审查, 决定授予专利权, 颁发实用新型专利证书并在专利公报上予以公告, 专利权自授权公告之日起生效, 专利期限为十年, 自申请日起算。

专利证书记载专利权的法律状况, 专利权的转移、质押、无效、终止、恢复和专利权的归属及名称、国籍、地址变更等事项记载在专利公报上。

局长 *申长雨*
 申长雨

2020年08月14日

第1页(共2页)

其他事项参见续页

Modern Life



Old Situation



Automatic/Touchless

Liquid 
soap dispenser

Foam 
soap dispenser

Hand disinfection

Model: SPD6108

Liquid Dispenser



Infrared Sensor



Visual capacity



1000ml Capacity

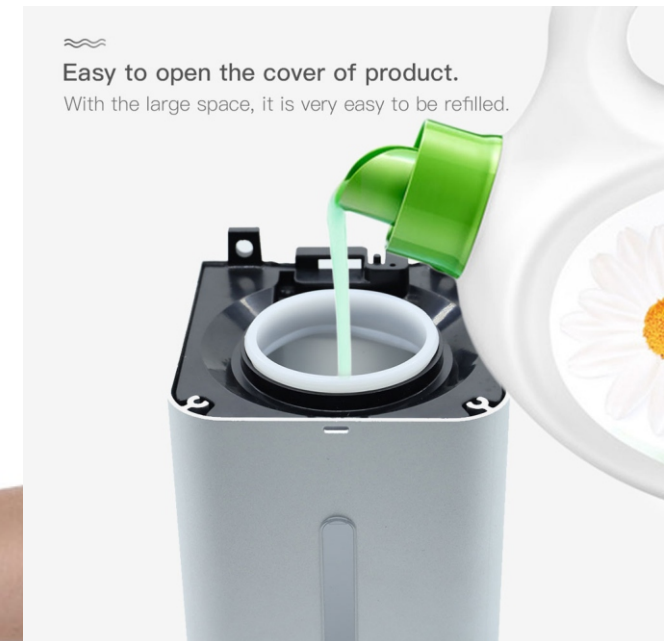



Technical Data.

SEONSSING
Clean your hands

Main features:

Clean your hands:

Our hands come into contact with countless bacteria and germs every day. That is why cleaning your hands with soap or disinfectant is very important. We have therefore made it our task to make this cleaning as easy as possible for you. With this dispenser, you get a soap dispenser and a disinfectant dispenser, depending on use, in one.

Widely used:

Soap dispenser has been widely used in home and commercial, such as rental houses, apartments, clinics, shops, offices, factories, restaurants and other public places.

- Automatic operation, touchless, avoiding cross infection
- **Equipped with the electromagnetic valve, permanently solve the liquid leakage problem.**
- Adjustable Soap Supply - Five level liquid soap supply from 0.5ml to 4ml(Different soap may have a slight deviation). suitable for all kinds of liquid, the hand soap, dish soap, hand gel sanitizer, hand disinfectant.
- One-piece design, do not need to take out the bottle refilling the liquid, easy maintenance, extending the product life
- Large capacity with 1000ml, especially suitable for commercial use.

Materials:

- Cover: Aluminium anodic oxidation
- Interior: ABS
- Bottle: PE
- Hardwares: Stainless steel 304

Specification

Product name:	Automatic soap dispenser
Operation:	Automatic/No touch
Nozzle type:	Liquid
Voltage:	DC6V/4AA batteries
Power supply:	A: 4 pcs AA battery B: AC/DC adaptor
Detect Distance:	5-8cm
Color:	Silver
Capacity:	1000ml
Liquid supply:	0.5-4ml
Installation:	Wall-mounted
Available Colors:	Silver/deep gray/rose gold

Model: SPD6108

Automatic soap dispenser

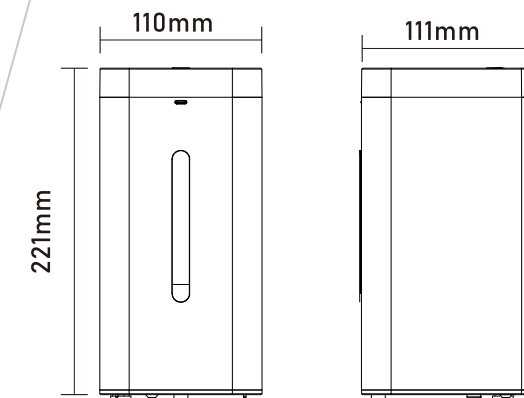

Shipping information:

Unit box size:	265X125X125mm
Unit gross weight:	1.2kgs
Master carton size:	510X380X260mm(12pcs)
Master carton gross weight:	14.5kg
20' GP load:	7200pcs
40'HQ load:	16320pcs

Foam Dispenser

Model: SPD6109



Infrared Sensor



Visual capacity



1000ml Capacity





Technical Data.

SEONSING

Clean your hands

Main features:

Clean your hands:

Our hands come into contact with countless bacteria and germs every day. That is why cleaning your hands with soap or disinfectant is very important. We have therefore made it our task to make this cleaning as easy as possible for you. With this dispenser, you get a soap dispenser and a disinfectant dispenser, depending on use, in one.

Widely used:

Soap dispenser has been widely used in home and commercial, such as rental houses, apartments, clinics, shops, offices, factories, restaurants and other public places.

- Automatic operation, touchless, avoiding cross infection
- **Equipped with the electromagnetic valve, permanently solve the liquid leakage problem.**
- Adjustable Soap Supply - Five level liquid soap supply from 0.5ml to 4ml(Different soap may have a slight deviation). suitable for foam soap, foam sanitizer, foam hand gel.
- One-piece design, do not need to take out the bottle refilling the liquid, easy maintenance, extending the product life
- Large capacity with 1000ml, especially suitable for commercial use.

Materials:

- Cover: Aluminium anodic oxidation
- Interior: ABS
- Bottle: PE
- Hardwares: Stainless steel 304

Specification

Product name:	Automatic foam soap dispenser
Operation:	Automatic/No touch
Nozzle type:	Foaming
Voltage:	DC6V/4AA batteries
Power supply:	A: 4 pcs AA battery B: AC/DC adaptor
Detect Distance:	5-8cm
Color:	Silver
Capacity:	1000ml
Liquid supply:	0.5-4ml
Installation:	Wall-mounted
Available Colors:	Silver/deep gray/rose gold

Model: SPD6109

Automatic foam soap dispenser

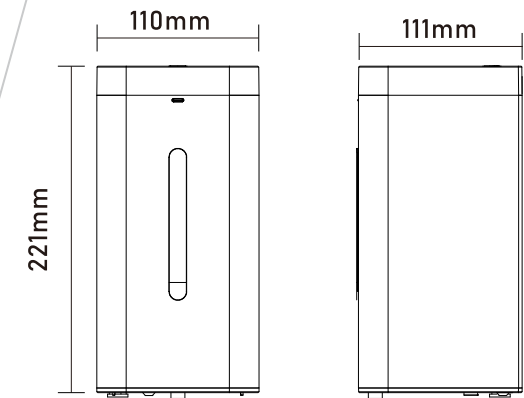

Shipping information:

Unit box size:	265X125X125mm
Unit gross weight:	1.2kgs
Master carton size:	510X380X260mm(12pcs)
Master carton gross weight:	14.5kg
20' GP load :	7200pcs
40'HQ load :	16320pcs

Hand disinfectant Spray mist

Model: SPD6110



Infrared Sensor



Visual capacity



1000ml Capacity



Stainless steel
mist outlet

Sensing
window

USB DC
power supply

5AA
battery



Refill Disinfectant

Suitable for Medical Alcohol,
Alcohol Hand Sanitizer,
Hand Disinfectant.





Technical Data.

SEONSSING

Clean your hands

Main features:

Clean your hands:

Our hands come into contact with countless bacteria and germs every day. That is why cleaning your hands with soap or disinfectant is very important. We have therefore made it our task to make this cleaning as easy as possible for you. With this dispenser, you get a soap dispenser and a disinfectant dispenser, depending on use, in one.

Widely used:

Soap dispenser has been widely used in home and commercial, such as rental houses, apartments, clinics, shops, offices, factories, restaurants and other public places.

- Automatic operation, touchless, avoiding cross infection
- **Equipped with the electromagnetic valve, permanently solve the liquid leakage problem.**
- Adjustable Soap Supply - Five level liquid soap supply from 0.5ml to 4ml(Different soap may have a slight deviation). suitable for medical alcohol, alcohol hand sanitizer, hand disinfectant.
- One-piece design, do not need to take out the bottle refilling the liquid, easy maintenance, extending the product life
- Large capacity with 1000ml, especially suitable for commercial use.

Materials:

- Cover: Aluminium anodic oxidation
- Interior: ABS
- Bottle: PE
- Hardwares: Stainless steel 304

Specification

Product name:	Automatic hand sanitizer
Operation:	Automatic/No touch
Nozzle type:	Spray mist
Voltage:	DC6V/4AA batteries
Power supply:	A: 4 pcs AA battery B: AC/DC adaptor
Sensing Distance:	5-8cm
Color:	Silver
Capacity:	1000ml
Liquid supply:	0.5-4ml
Installation:	Wall-mounted
Available Colors:	Silver/deep gray/rose gold

Model: SPD6110

Automatic hand sanitizer

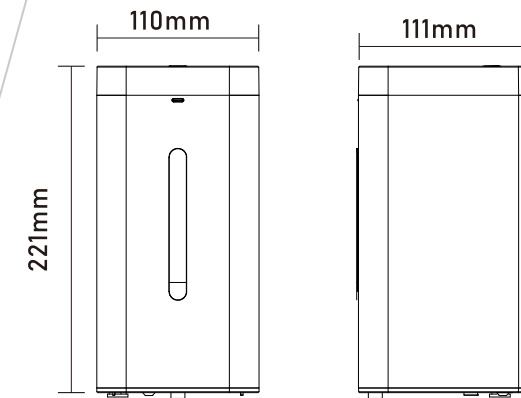

Shipping information:

Unit box size:	265X125X125mm
Unit gross weight:	1.2kgs
Master carton size:	510X380X260mm(12pcs)
Master carton gross weight:	14.5kg
20' GP load :	7200pcs
40'HQ load :	16320pcs